

Table of Contents

Company Introduction	2
What is an Inclined Platform Lift?	3
Why an Inclined Platform Lift?	3
Design Versatility	4
Where You'll Find Our Lifts	5
Finishes	6
How it Works	7
Component Identification	8
Platform	9
Standard Platform Safety Features	10
Optional Platform Features	11
Drive System	12
Guide Tubes	13
Call Stations	14
Additional Component Options	15
Lower Landing Configuration Options	16
Required Turning Clearances	18
Standard Upper Landing Drive Configurations	20
Alternate Drive Configurations	21
Platform Storage at Upper Landing (Optional)	23
Platform Running Clearances Required for Platform Folded Up	24
Minimum Overhead Clearances to Meet Code Requirements	24
Attachment Methods	26
Wall Height Requirements for Direct Mounting	28
Loading Diagram	29
Technical Reference of Standard Features	30
Typical Wiring Layout	31

Garaventa - the world's #1 choice for accessibility solutions.

Garaventa has been dedicated to developing safe and reliable accessibility solutions since 1978 and is now an industry leader worldwide. Years of hard work and an uncompromising commitment to quality have enabled us to perfect the internationally renowned Garaventa Stair-Lift. This same commitment has led Garaventa to develop other accessibility products such as the GSL Xpress inclined platform lift and the Genesis vertical platform lift.

The Genesis vertical platform lift incorporates state of the art features with elegant styling and quiet operation. The Genesis has a variety of models and configurations with many standard and optional features to choose from. With the development of the Genesis vertical platform lift, Garaventa has taken a significant step towards solving most accessibility challenges for building owners.

The GSL Xpress is a new generation inclined platform lift for straight stairways. The sleek and attractive Xpress can be installed indoors or outdoors and is a cost-effective access solution. The Garaventa GSL Artira described in this Design and Planning Guide is able to follow straight or curving stairways, up several flights of stairs and across horizontal landings. It is suitable for indoor and outdoor applications with many standard and optional features allowing the GSL Artira to be customized to meet the needs of the user.

With endorsements from leading designers, architects and planners, custom designed Garaventa Stair-Lifts have been installed in over 15,000 sites worldwide. Garaventa Stair-Lift installations include the high profile locations of 10 Downing Street, Harvard Business School, and the National Art Gallery of Ottawa.

Our expertise in providing accessibility solutions has enabled our design team to undertake the most challenging access problems or issues and develop innovative solutions for schools, places of worship, offices, hotels, airports, subways, and a wide range of public and private buildings around the world.

We have built our business on service. Please contact us and let us help solve your accessibility challenges.



©2002 Garaventa. As we are continuously improving our products, specifications outlined in this guide are subject to change without notice.

What is an Inclined Platform Lift?

An inclined platform lift easily transports a passenger, in a wheelchair or someone who has difficulty maneuvering stairs up and down a stairway. The lift can be operated independently or by an attendant with a attendant remote control (optional item). Compatible for indoor and outdoor applications, the **Garaventa Inclined Platform Lift** is a versatile, attractive and cost-effective accessibility solution.

Why an Inclined Platform Lift?

No Building Renovations (Modifications)

Inclined platform lifts fit easily into most stairways and do not require specially constructed hoistways.

Preserve Heritage Buildings

Flexibility in design enables Garaventa's designers to adapt an inclined platform lift to virtually any building site with very little or no structural modifications. The availability of many colors and finishes ensures the lift will blend with its environment and preserve the look of a heritage building.

Save Valuable Floor Space

Building floor space, whether a business or a school is valuable. Inclined platform lifts utilize very little of this expensive commodity.

Meet ADA Requirements

Garaventa inclined platform lifts are approved in the ADA Accessibility Guidelines as a means to provide public building access when licensed for independent operation. They may also be used as an accessible means of egress when equipped with an auxiliary standby power system.

Design Assistance

With over 25 years of experience, Garaventa is willing and able to overcome almost any design challenge you face. Please call our Design Hot Line with your accessibility challenge.

1-800-663-6556 or 1+604-594-0422

Design Versatility

The GSL Artira can be designed for **turning, straight** or **radiating stairways** with or without **intermediate landings**. It is suitable for multi-level buildings with a wide variety of design configurations.

Some of the many design configurations include:

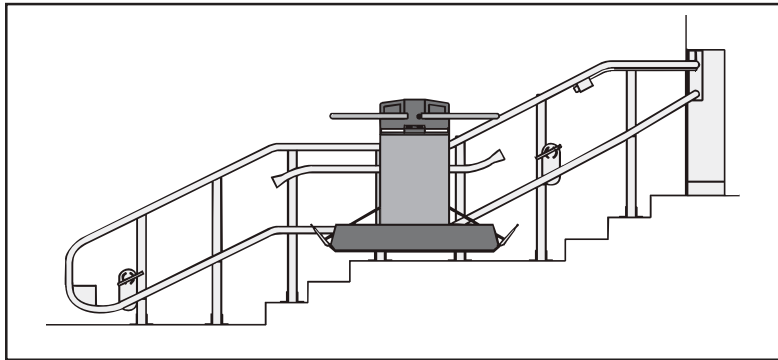

Straight Stairway with Horizontal Landing

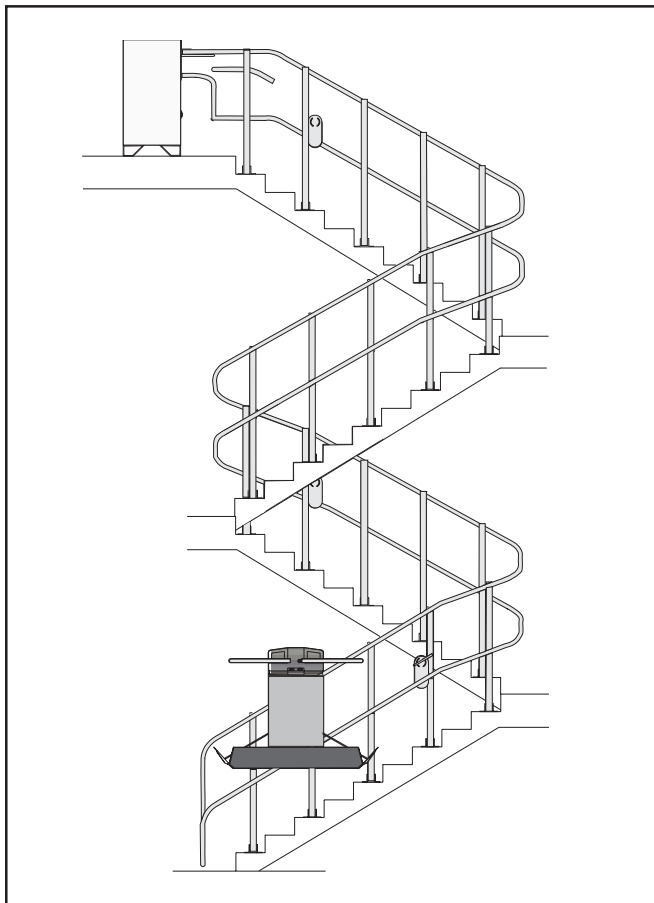

Turning Stairway in Multi-Level Building

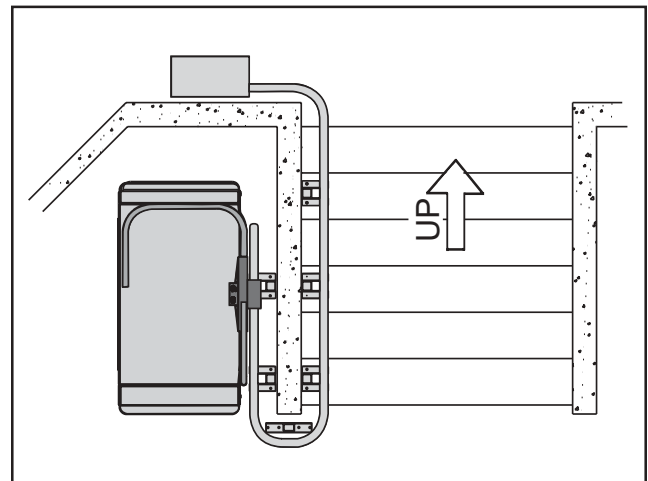

Straight Stairway with Platform Storage

Applications Include:

- Schools
- Courthouses
- Theaters
- Restaurants
- Hospitals
- Churches
- Commercial Buildings
- Historical Buildings
- Residential
- And Many More

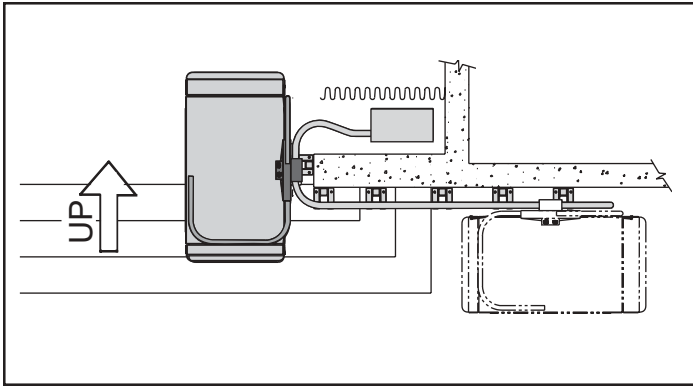

Unusual Landings:

An ideal layout for stages or store entrances.

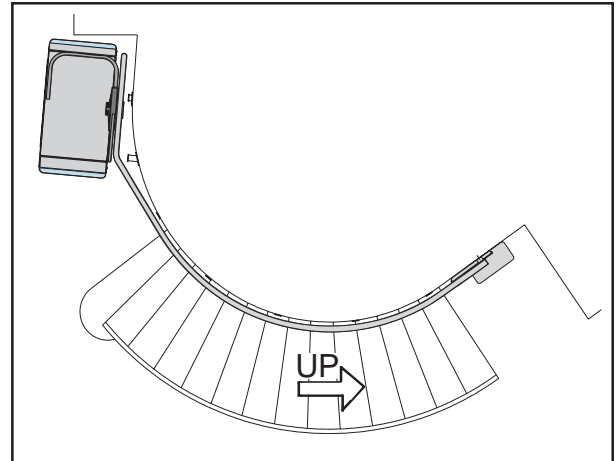

Radiating Stairs:

Found in installations such as hotel lobbies or observatories.

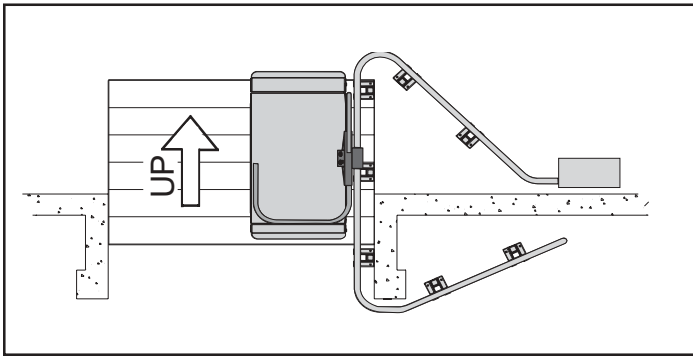

Unusual Bends:

For applications such as theaters, restaurants or lecture halls.

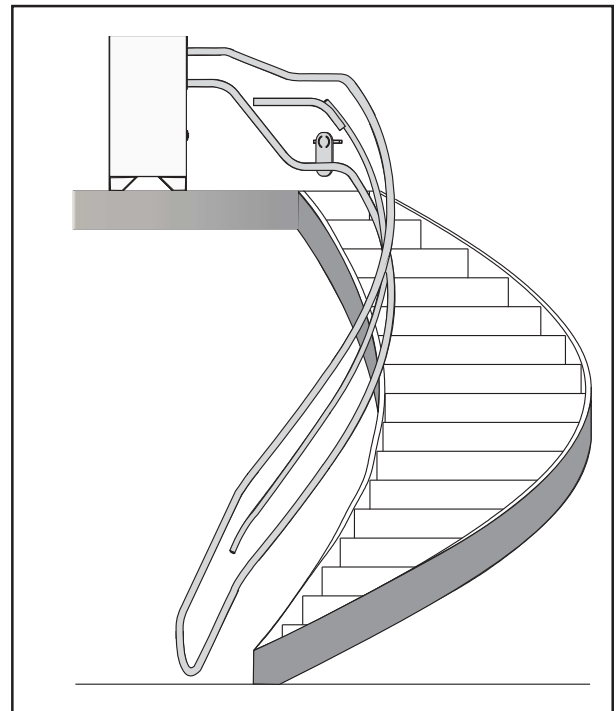

Spiral Stairs:

Grand staircases in hotels or theaters.

Where You'll Find Our Lifts

Over 15,000 installations world wide. Some of our well-known installations include:

- National Art Gallery - Ottawa, ON, Canada
- Presidential Palace - Seoul, Korea
- City Hall, San Francisco, CA, USA
- #10 Downing Street - London, England
- The Peak - Hong Kong
- Madison Square Garden - New York, NY, USA
- Vancouver City Hall - Vancouver, BC, Canada
- Harvard Business School - Cambridge, MA, USA
- Metro System - Santiago, Chile & Mexico City, Mexico
- BART (Bay Area Rapid Transit), San Francisco, CA, USA
- Safeco Field, Seattle, Washington, USA

For a list of installations in your area, please contact your local representative or call Garaventa.

Finishes

The GSL Artira is finished in a durable polyester powder paint coating that is electrostatically applied and baked at 210° C (410° F).

Standard Color

Garaventa's standard color, Satin Grey (fine textured), complements a variety of modern and traditional decors (color samples are available upon request).

Custom Colors (Optional)

Garaventa also offers a choice of colors from the internationally accepted RAL color charts (color samples are available upon request).

Stainless Steel Finish (Optional or for Outdoor Applications)

For aesthetic purposes the tubes, towers, drive box, sensing plate and call stations can be ordered in an electro-polished stainless steel finish. Stainless steel components are also available in a painted finish.

Outdoor Applications

When located outdoors, the lift will be equipped with outdoor compatible components. See page 15 for more information on the outdoor weather-resistant package. For outdoor units, stainless steel components are also available in a painted finish.

Note: In certain indoor applications such as near a swimming pool, an outdoor weather-resistant package may be required.

How it Works

Two **steel guide tubes** which are custom designed for each stairway support the **platform**. These tubes contain a continuous loop of **wire haul rope** that is attached to the **upper carriage**. This carriage is mounted to the back of the platform through a slot in the upper tube. The **drive system**, consisting of an electric motor and **drive cog**, moves the wire haul rope and the wheelchair platform up and down the stairway.

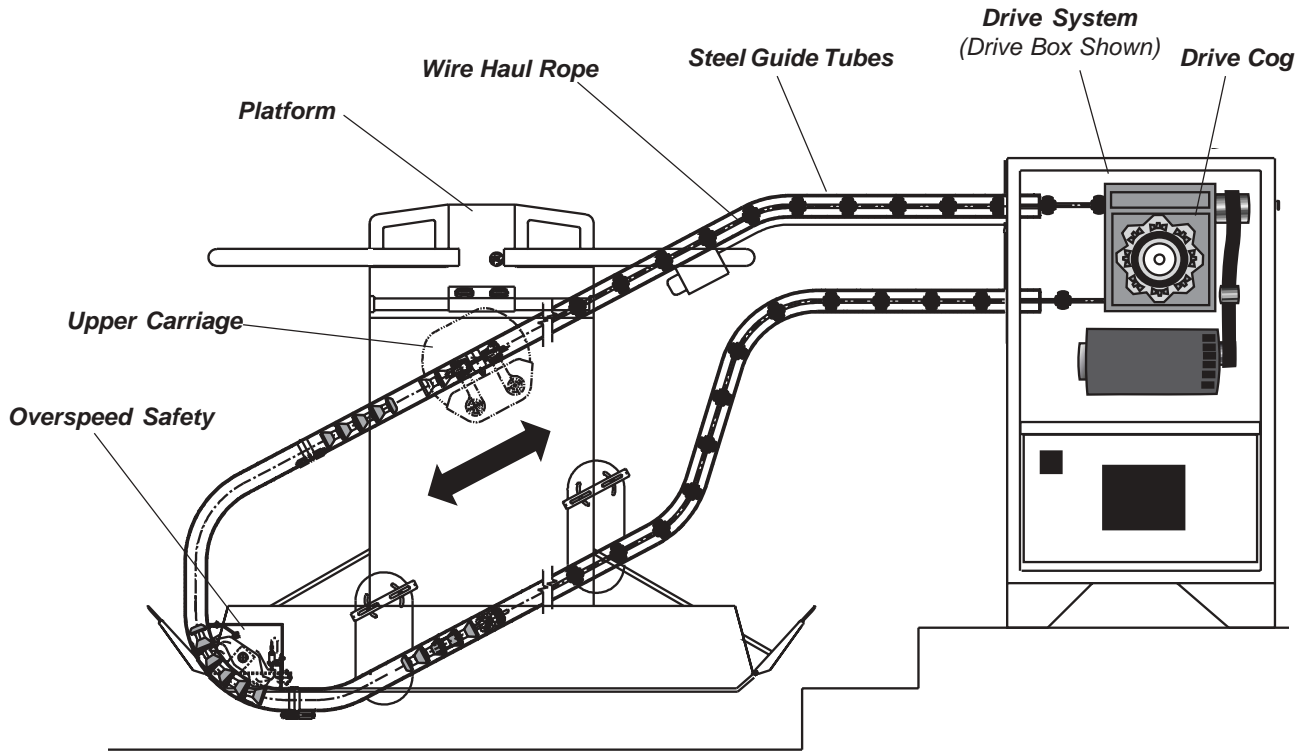

Section Through Tubes and Drive System

Overspeed Safety

The Overspeed Safety is located at the lower end of the tube system and consists of a mechanical pawl and electrical cut-out switch. In the unlikely event that the lift should descend too quickly, both the mechanical and electrical safety will activate simultaneously and stop the platform from moving.

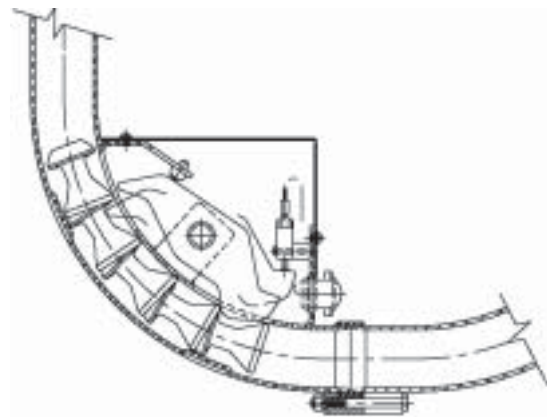

Overspeed Safety

Component Identification

The main components of an inclined lift are:

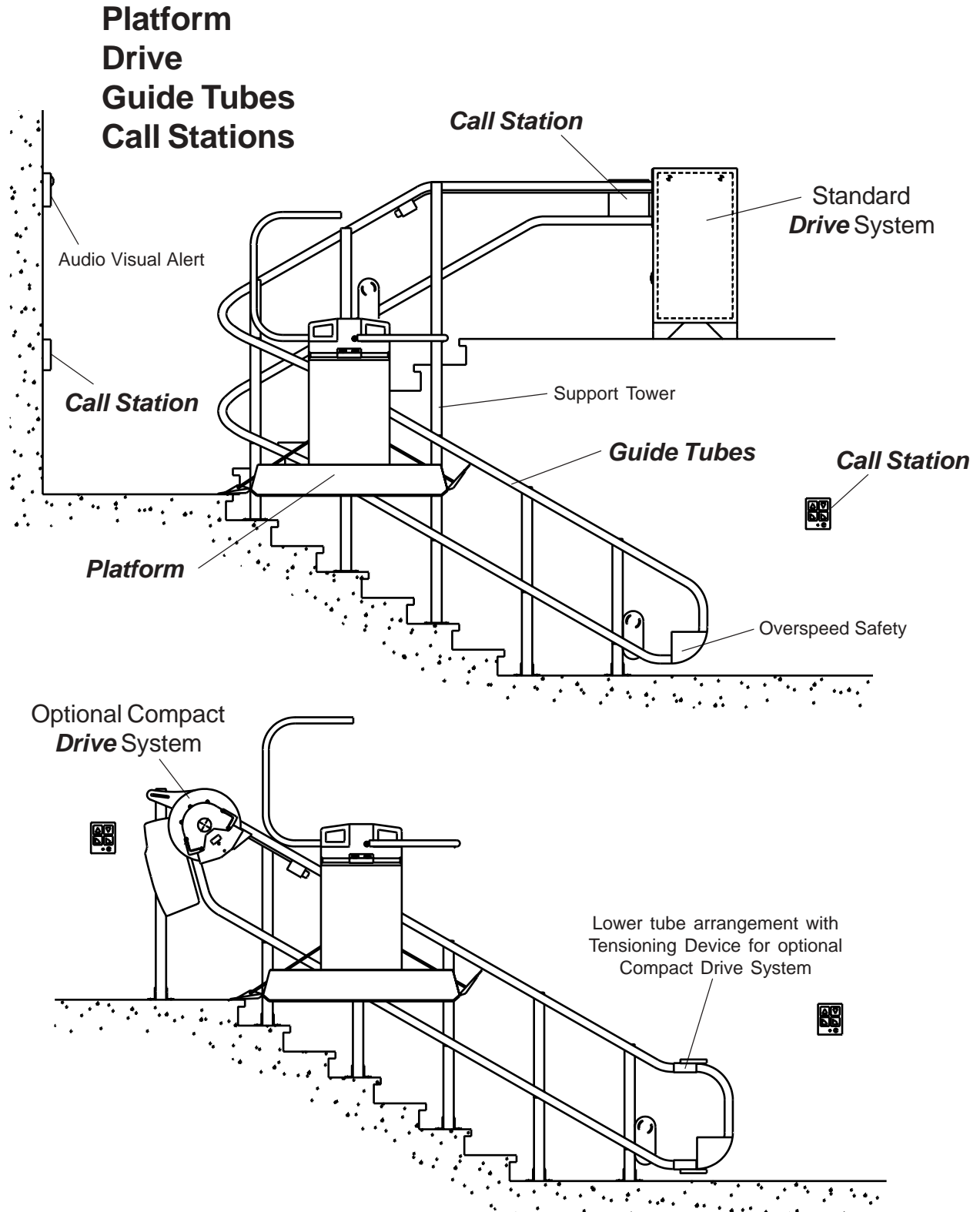

Platform

Platform Sizes

The platform is available in four sizes, all with a rated load of 250 kg. (550 lbs.).

- 800 x 1220mm (31 1/2" x 48")
- 800 x 1050mm (31 1/2" x 41 3/8")
- 800 x 900mm (31 1/2" x 35 3/8")
- 700 x 750mm (27 1/2" x 29 1/2")

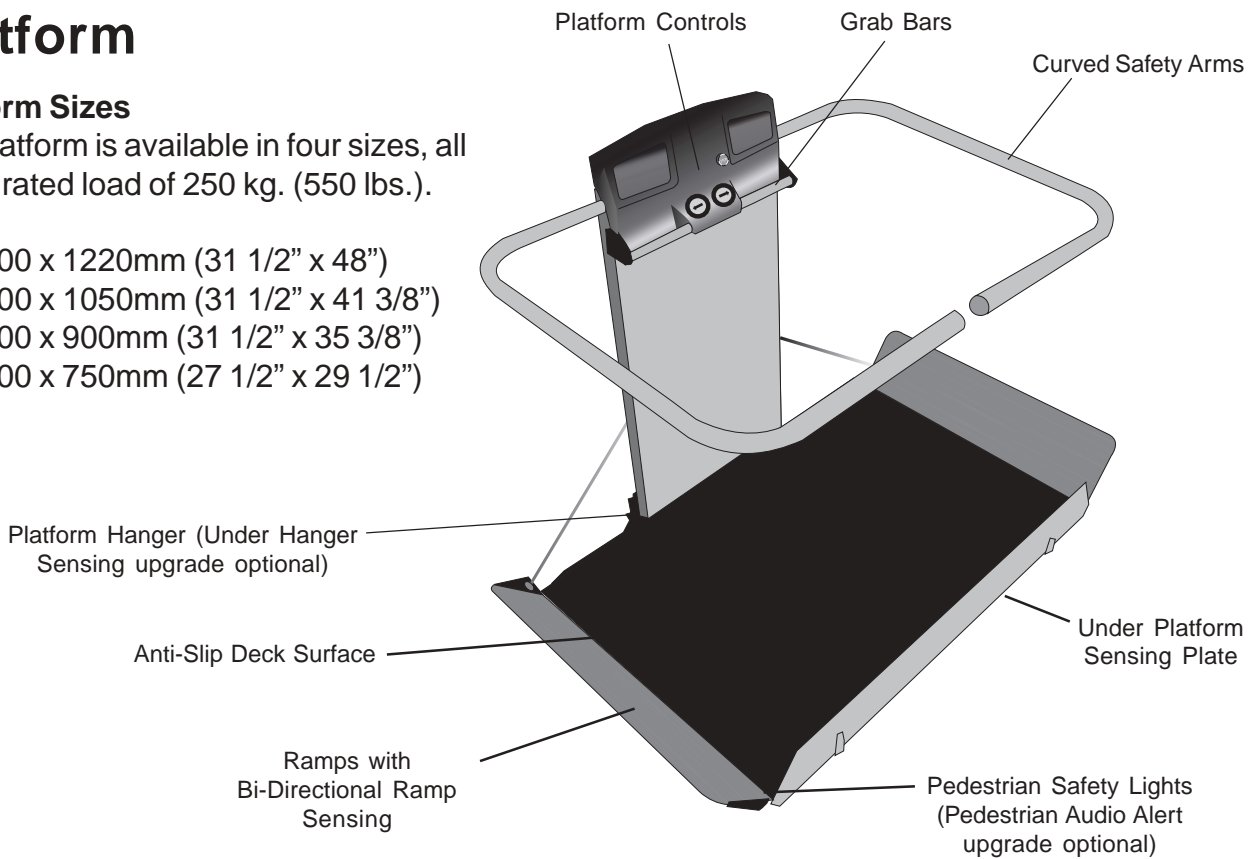

Platform Components

Platform Control Panel

The durable and vandal resistant platform control panel is mounted to the platform hanger. The standard platform controls consist of two large illuminated **Directional Buttons** for independent operation and an **Emergency Stop Button** (with illumination optional).

Attendant Remote Control Unit

The platform can be equipped with an optional **Attendant Remote Control** that overrides the **Directional Buttons** during attendant operation. The remote control unit can be removed when not required.

Standard Platform Safety Features

Safety Sensing

The platform is equipped with safety sensors listed below. These sensors will automatically stop the lift when activated by 1.8 kg (4 lbs.) of pressure. The platform can then be backed away from the obstruction allowing the object to be removed.

Leading Ramp Sensor

When the platform is called to or from the landing area in the folded up position the leading ramp is sensitive to obstructions.

Under Platform Sensing Plate

The under platform sensing plate detects obstacles underneath the platform.

Bi-Directional Ramp Sensing

The ramps are designed to be obstruction sensitive in the direction of travel on the outside of the ramps as well as from within the platform. The internal ramp sensor prevents a wheelchair from being off-center on the platform deck.

Curved Safety Arms

Fully automatic 32mm (1 1/4") diameter Curved Safety Arms further increase the safety of the GSL Artira. When in the guarding position the inside dimensions of the arms do not take away from the clear platform size. The top of the arm is located 948mm (37 3/8") above the platform deck. If arms should encounter an obstruction, they will automatically retract to the up position.

Emergency Stop Button

Located on the platform control panel, this large red button is used to stop the lift in an emergency.

Smooth Start & Stop

For passenger safety and comfort, the platform is programmed to slow to 50% of the normal travel speed well in advance of the corners and resumes full speed when the platform reaches the straight section of the stairs. The lift controller is also programmed to slow the platform travel speed when approaching and departing landings.

Grab Bars

These 32mm (1 1/4") diameter aluminum bars are located on the front face of the platform control panel to assist passengers in loading and unloading.

Pedestrian Safety Lights

This illuminated tube lighting located at the base of the ramps visually alerts pedestrians of the platform's location during travel, while still being discreet to the passenger.

Emergency Fold

In an emergency the platform is able to be manually folded and will lock in the folded position.

Optional Platform Features

Platform Lock

This lock secures the platform in its folded position protecting the unit from vandalism.

Under Hanger Sensing

When the platform moves to or from the landing area in the folded up position, sensors on the underside of the hanger will automatically stop the lift when activated by a minimum of 1.8 kg (4 lbs.) of pressure.

Pedestrian Audio Alert

When the platform is folded up and traveling between stations, an audio chime on the platform is activated indicating the lift is in motion. The chime is deactivated when a passenger is using the lift.

Folding Seat

Designed for use by ambulatory passengers, this folding seat is equipped with a safety belt.

Dek-Lite

Mounted below the folding seat, this light illuminates the platform for safe loading and unloading, ideal for areas with poor lighting (only available with the folding seat option).

Side Load

Designed for confined lower landing spaces, this feature opens a side ramp simultaneously with both of the end ramps. This allows the passenger to wheel onto the platform diagonally, offering easier access and reducing the required loading and unloading clearances.

Auto Fold

This feature will allow the lift to automatically fold if left unattended for a period of time at a landing. This ensures the stairway remains clear in the event someone forgets to fold the lift.

Platform on Board Alarm

If the platform Emergency Stop Button is activated it illuminates and an alarm located on board the platform will sound alerting others that the passenger on the lift requires assistance.

Attendant Remote Control

A hand held remote control plugs into a socket on the platform control panel and overrides the platform controls allowing an attendant to operate the lift.

Key Switch

To meet some local code requirements a key switch can be added to the platform control panel.

Illuminated Emergency Stop Button

The emergency stop button can be illuminated when required by code.

Note: In some areas certain optional features are either not permitted or mandatory depending on local codes. Please consult your local Garaventa representative for clarification.

Drive System

The drive always located at the upper end of the guide tubes is available in two arrangements: the **Drive Box** and the **Compact Drive**. Each drive system is suited to a particular application, with a variety of design configurations to choose from (see pages 20-22 for drive configurations).

Mains Power Requirements

Both drive systems require 208-240 VAC single-phase 50/60 Hz., on a dedicated 20 amp. circuit.

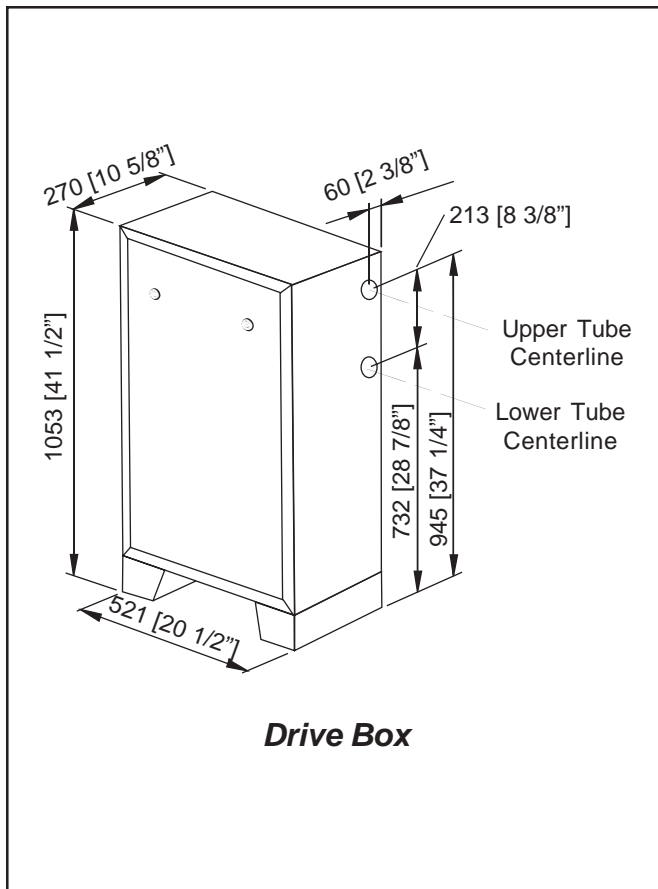

Drive Box

The **most common** drive arrangement, the Drive Box, uses a 3 phase (supplied by inverter) **1.5 H.P. motor** and is always attached to the upper end of the guide tubes.

The drive box has a **multitude of design configurations** (under the floor through the wall and many more). Please see page 20-22 for some of the many design options available.

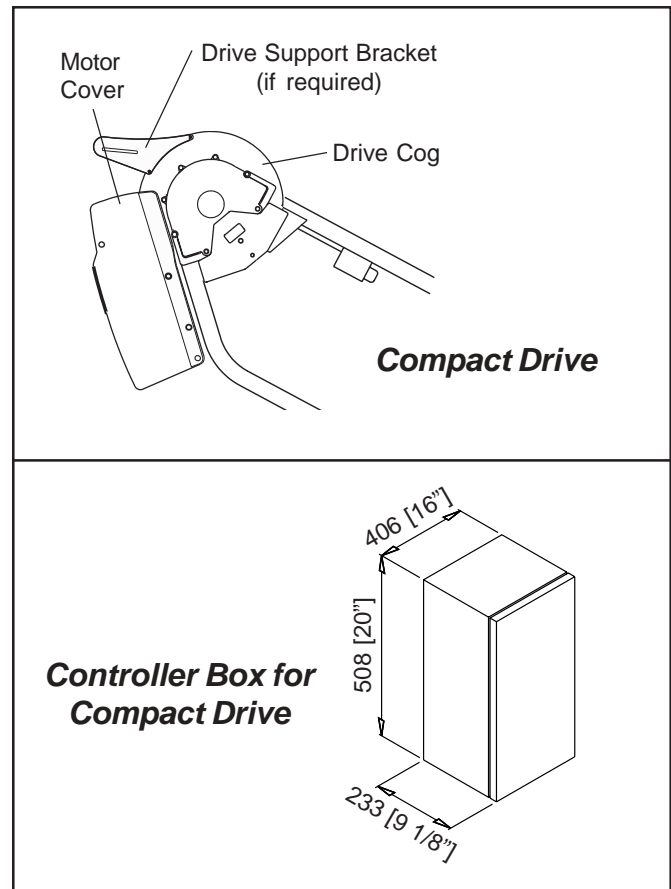

Compact Drive

The compact drive is ideal for lifts with **restricted upper landings**. It utilizes the same components as the Drive Box however, they are arranged differently. The drive cog and the motor are directly attached to the upper end of the guide tube system, with the electrical components housed in a **Controller Box** that can be **located up to 6 meters (20ft) away from the compact drive**.

This drive arrangement utilizes a tensioning device at the lower landing (see page 16).

Guide Tubes

The platform travels on two steel tubes, **51mm (2") in diameter**, that are **affixed 600mm (23 5/8") apart vertically**. The location of the tubes on the stairs depends on the platform size and the angle of the stairs. Generally speaking, the lower tube is approximately 500mm (21 5/8") vertically above the stairs when a 800 x 1220 mm (31 1/2" x 48") platform is used.

Stabilizer

The stabilizer tube is placed in horizontal or shallow sections of the lift's travel. This slotted tube allows a roller, mounted to the back of the platform, to enter and travel through. This roller connection creates a triangle of support to stabilize the platform. The stabilizer is **required whenever the lift travels horizontally or at an angle of less than 20°**.

Pedestrian Handrails (Optional)

With the installation of the tube system the existing handrails are often obstructed or removed. A third tube, **38mm (1 1/2") in diameter**, can be located between the main guide tubes to serve as a pedestrian handrail. In most applications this handrail **can be positioned within the accepted code height range**.

Some restrictions apply when used in conjunction with the horizontal stabilizer (see above for further details on the stabilizer). Contact your local Garaventa representative or call the Garaventa Design Hot Line for more information.

Infill Panels (Optional)

These mesh screens are located between the towers of the lift to create a safety barrier.

As an alternative attachment angles can be welded to the sides of the towers to allow for infill panels of other materials, such as Plexiglas or wood (infill panel material is not supplied by Garaventa).

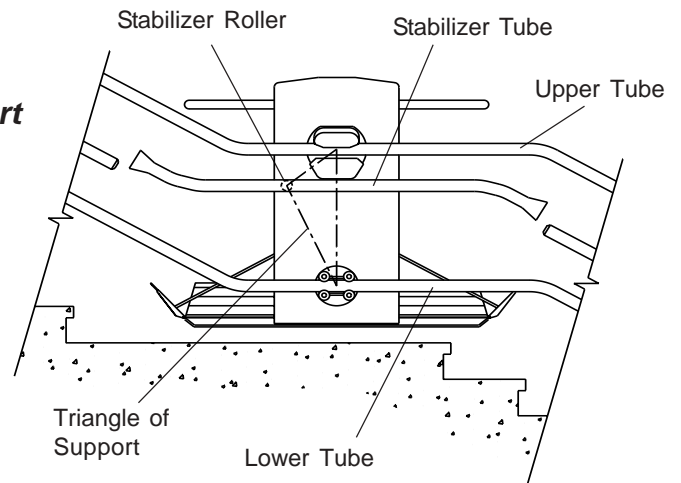

Horizontal Stabilizer

(back of platform shown)

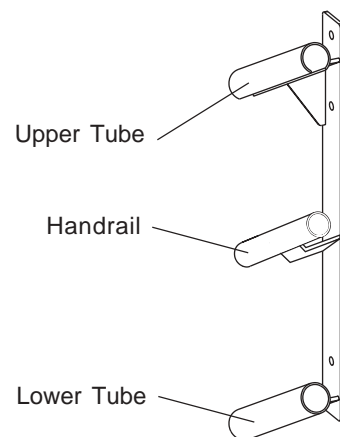

Pedestrian Handrail

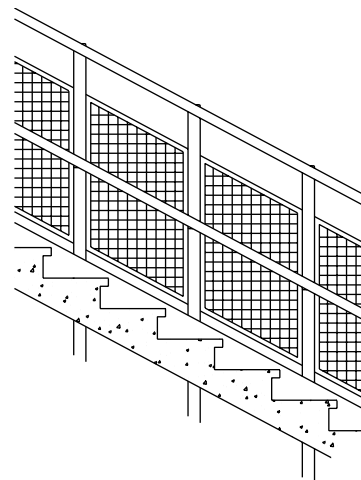

Infill Panel

Call Stations

Each landing is equipped with a call station. The call station enables the user to unfold the platform with a touch of a button. If the platform is not at their landing the user simply presses the illuminated directional button to bring the platform to their landing.

Garaventa Smart-Lite Technology™

When the call station is turned on the Artira's Smart-Lite Technology™ illuminates the correct call station button, guiding the user through the sequenced steps to call and unfold the lift from the call station (patent pending).

Call Station Options

To meet customer or code requirements an optional **Emergency Stop Button** (with illumination optional) and an **Attendant Call Switch** can be added to the call station.

Keyless (optional)

A keyless call station is available as an option. The keyless lift does not have a keyswitch on the call station.

Remote Fold (optional)

This feature allows the platform to be folded up from any call station should the platform be left folded down.

Mounting Options

The call stations can be mounted on the wall (surface or flush mounted) or on a pedestal (when no suitable surface is available). The upper call station can also be mounted on the drive box or on the tube system itself (only available with Drive Box arrangement). Flush mount call stations can be pre-wired during the construction or building renovations, resulting in a cleaner appearance with no surface wiring.

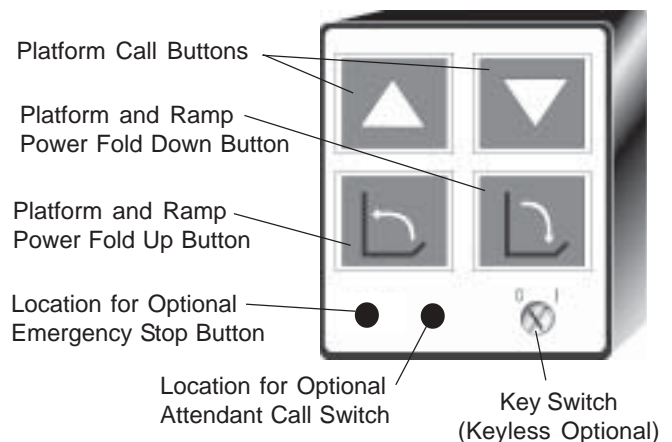

Call Station

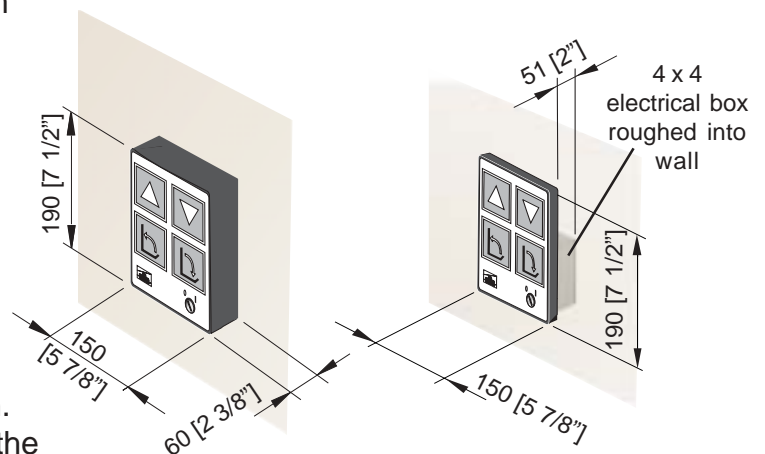

Surface Mount Call Station

Flush Mount Call Station (optional)

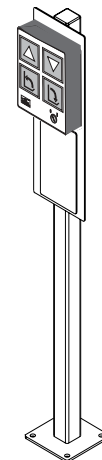

Freestanding Call Station Pedestal (Optional)

Additional Component Options

The GSL Artira can be equipped with a number of additional safety features:

Audio Visual Alert

When the lift is in use, a wall mounted strobe light and audible chime cautions pedestrians in the vicinity that the lift is in operation. The volume of the audible chime can be adjusted on site.

Fire Alarm Integration (Fire Service)

There are two versions of the fire service, both are designed to interface with a building's fire safety system and interrupt power to the lift when the fire alarm sounds. This **ensures the lift will not obstruct stairway traffic during evacuation**. If the lift is in use when the alarm sounds, the lift will only allow the platform to travel to the designated landing with the emergency exit. The "manual" version requires the passenger to use the constant pressure direction button. The "auto" version is programmed to **travel to the designated landing with the emergency exit, without assistance from the passenger**.

Auxiliary Power System

This feature ensures that the **lift continues to operate during a power outage**. The self contained battery unit **can be located up to 4.5 meters (15') away** from the drive system and will **power the lift up to one hour at full capacity**. This time may vary depending on the lift length and number of bends.

Box Size: 597 mm (23 1/2") high x 444 mm (17 1/2") wide x 192 mm (7 5/8") deep

Outdoor Applications

When located outdoors, the lift will require stainless steel tubes, towers and audio visual alerts (if specified). An outdoor platform is zinc plated and includes a cap on the attendant remote control socket and weather-resistant sealant on the electrical components. The outdoor Drive Box is weather-resistant and available in a zinc-plated finish (with a painted finish) or polished stainless steel.

Note: In certain indoor applications such as near a swimming pool, an outdoor weather-resistant package may be required.

Lower Landing Configuration Options

A variety of lower landing configurations are available to suit each stairway. If you have a unique arrangement, contact your local Garaventa representative or call the Garaventa Design Hot Line for more information.

Straight Lower Landing for Drive Box

This configuration is used when there is adequate space to load/unload straight onto the platform at the lower landing.

Drop-Down Lower Landing

(Drive Box System Shown)

When lower landing space is limited, the lower landing section of the tubes are angled downward at a 45° angle to land the platform as close to the bottom step as possible. This configuration is often combined with the side load feature.

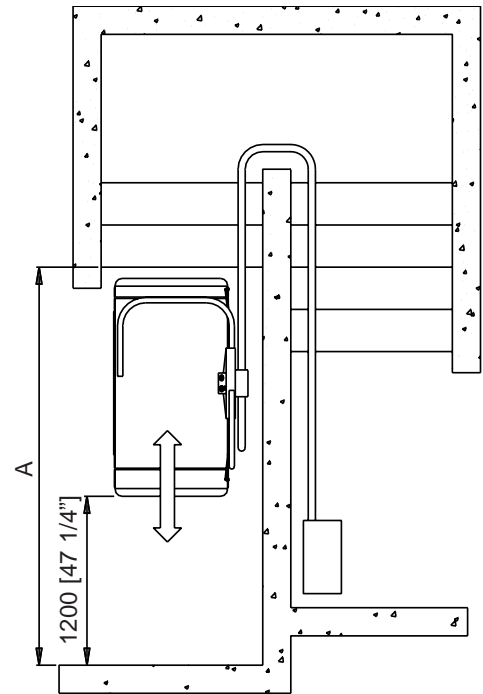
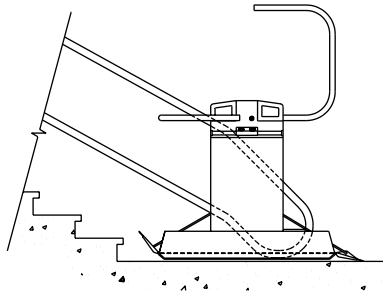

Straight Lower Landing

Straight Lower Landing for Compact Drive

The Rope Tensioning Device used with the Compact Drives requires a minimum clearance of 250mm (9 7/8") from the end of the tubes to the nearest obstruction.

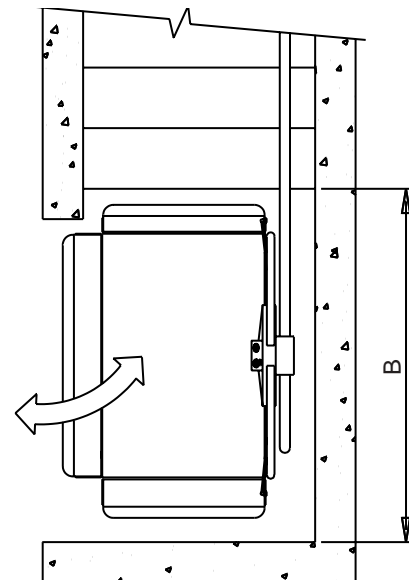
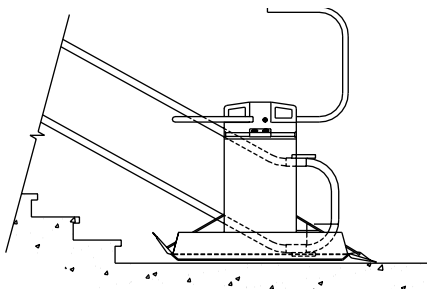

Straight Landing - With Side Load

90° and 180° Lower Landings

These configurations place the platform away from pedestrian traffic while loading/unloading and storing the platform. Ideal for stairs with sufficient clearances such as stairways with alcoves, hallways or otherwise unused spaces under stairs.

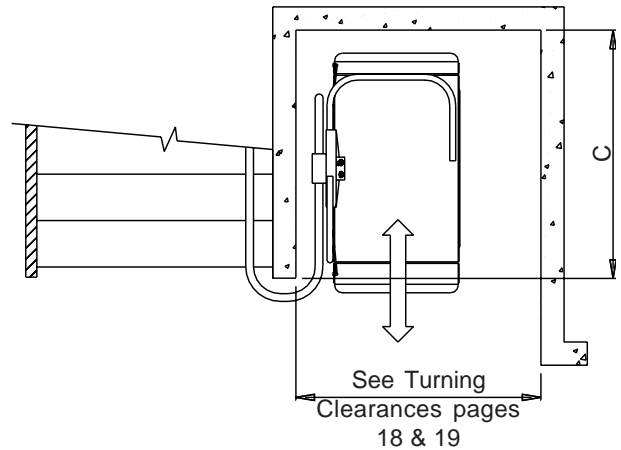
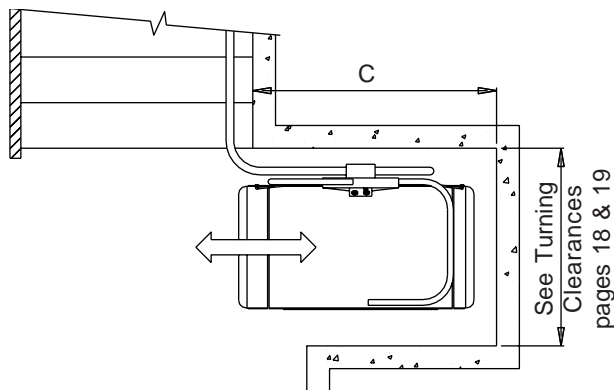

Required Lower Landing Clearances

Platform Size	Dim. A	Dim. B	Dim. C
800 x 1220 mm (31 1/2" x 48")	2883 (113 1/2)	1708 (67 1/4)	1540 (60 5/8)
800 x 1050 mm (31 1/2" x 41 3/8")	2713 (106 3/4)	1538 (60 1/2)	1370 (53 7/8)
800 x 900 mm (31 1/2" x 35 3/8")	2563 (100 7/8)	1388 (54 5/8)	1220 (48)
700 x 750 mm (27 1/2" x 29 1/2")	2368 (93 1/4)	1218 (48)	1070 (42 1/8)

Notes:

- Dimension A has been calculated using a drop-down landing configuration and a first riser height of 178mm (7").
- Dimensions are based on standard platforms with standard ramps. Ramp extensions will increase the clearances required.
- Contact your local Garaventa representative or call the Garaventa Design Hot Line for more information.

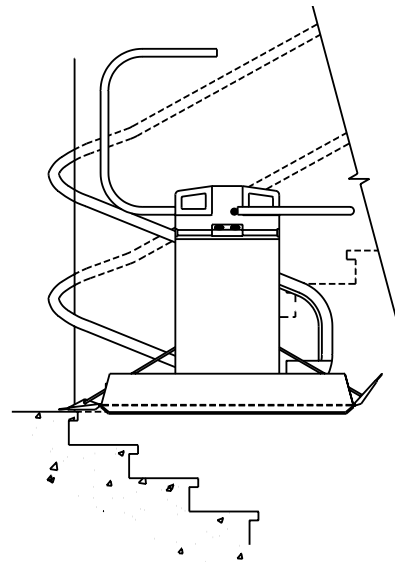

Landing Over a Flight

This enables the platform to be loaded/unloaded and stored over a flight of stairs that is not being serviced by the lift.

Required Turning Clearances

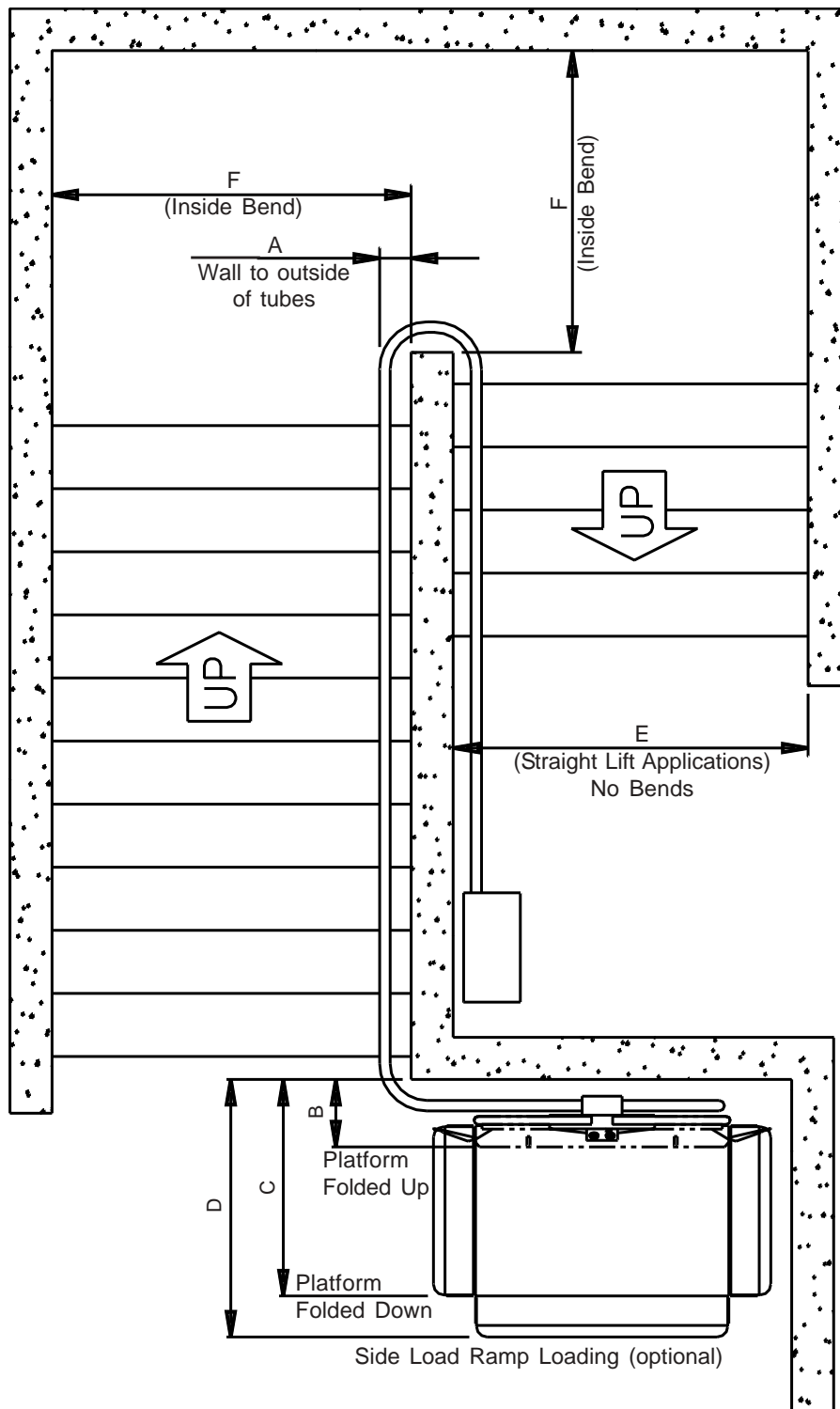

Stair Width Clearances and Platform Projection Dimensions

Turning Clearance Chart

The space requirements of the GSL Artira are affected by how the tube system is supported. The lift can either be mounted directly to the wall, **Direct Mount**, or structural support posts can be supplied **Tower mount**. For further information on Attachment Methods please refer to page 26 & 27.

Dim.	Attachment Method	Platform Sizes							
		800 x 1220 mm (31 1/2" x 48")		800 x 1050 mm (31 1/2" x 41 3/8")		800 x 900 mm (31 1/2 x 35 3/8")		700 x 750 mm (27 1/2" x 29 1/2")	
		mm	in	mm	in	mm	in	mm	in
A	Direct Mount	125	4 7/8	125	4 7/8	125	4 7/8	125	4 7/8
	Tower Mount	150	5 7/8	150	5 7/8	150	5 7/8	150	5 7/8
B	Direct Mount	320	12 5/8	320	12 5/8	320	12 5/8	330	13
	Tower Mount	345	13 5/8	345	13 5/8	345	13 5/8	355	14
C	Direct Mount	1015	40	1015	40	1015	40	900	35 3/8
	Tower Mount	1040	41	1040	41	1040	41	925	36 3/8
D	Direct Mount	1230	48 3/8	1230	48 3/8	1230	48 3/8	1115	44
	Tower Mount	1255	49 3/8	1255	49 3/8	1255	49 3/8	1140	45
E	Direct Mount	1035	40 3/4	1035	40 3/4	1035	40 3/4	920	36 1/4
	Tower Mount	1060	41 3/4	1060	41 3/4	1060	41 3/4	945	37 1/4
F	Direct Mount	1225	48 1/4	1185	46 5/8	1145	45 1/8	1025	40 3/8
	Tower Mount	1250	49 1/4	1210	47 5/8	1170	46 1/8	1050	41 3/8

Note:

- Dimensions E and F includes 20mm (3/4") running clearance and include standard ramps. Ramp extensions will increase the clearances required. Contact your local Garaventa representative or call the Garaventa Design Hot Line for more information.
- For towers mounted to 2" x 6" wood boards on walls (see page 26) add 38mm (1 1/2") to the above tower mount dimensions.

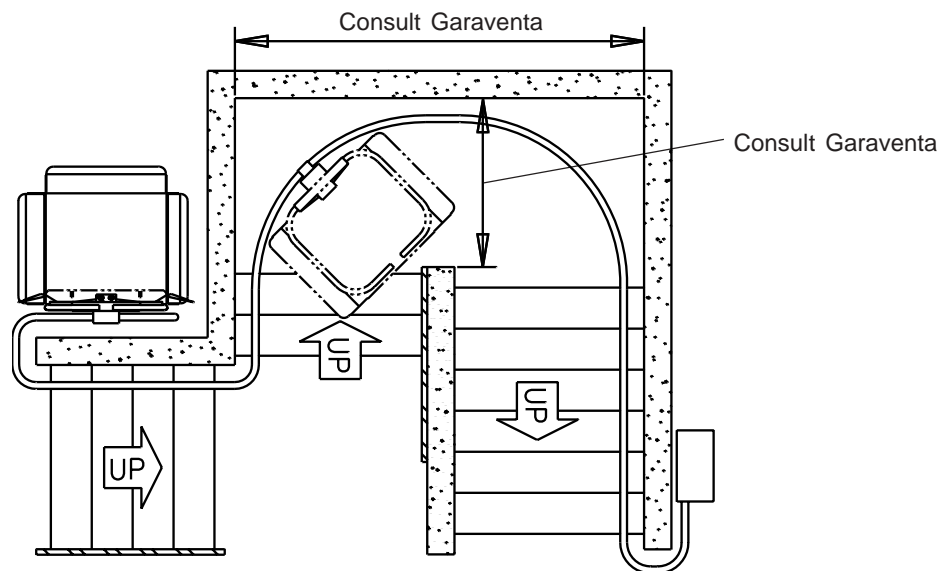

Consult Garaventa for Clearances of Outside Radius Bends

Standard Upper Landing Drive Configurations

A variety of configurations are available for each drive system. If you have a unique or complex application that is not covered in this guide, contact your local Garaventa representative or call the Garaventa Design Hot Line for more information.

Standard In-Line Drive

The standard in-line drive configuration places the drive 1200mm (47 1/4") from the top of the stairs to allow a passenger to load and unload the platform and maneuver past the Drive Box.

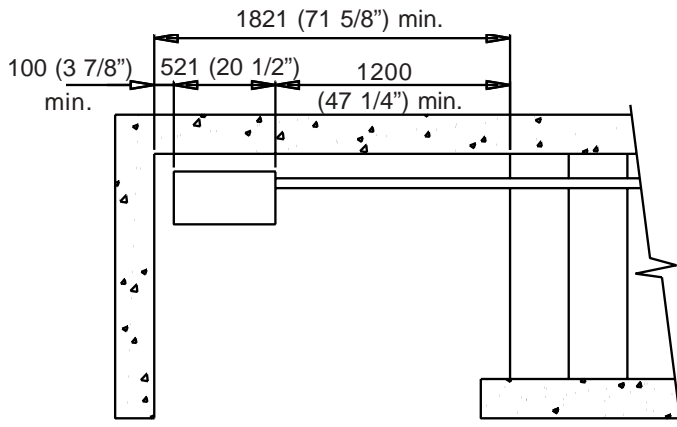

Offset Drive

When upper landing space is limited, the Drive Box can be positioned closer to the stairs and to the wall.

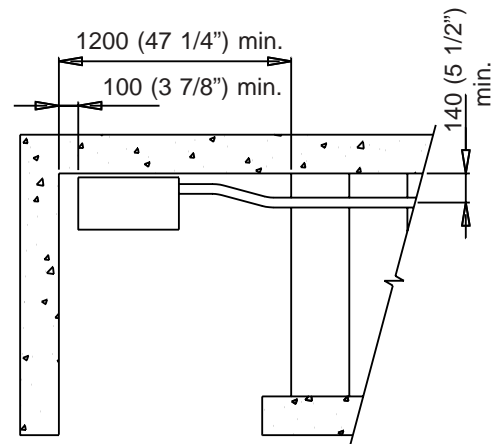

90° & 180° Drive

The 90° or 180° configuration allows the drive box to be located away from the top of the stairs and pedestrian traffic.

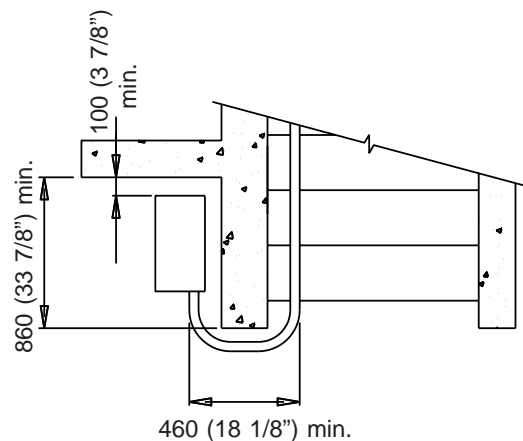
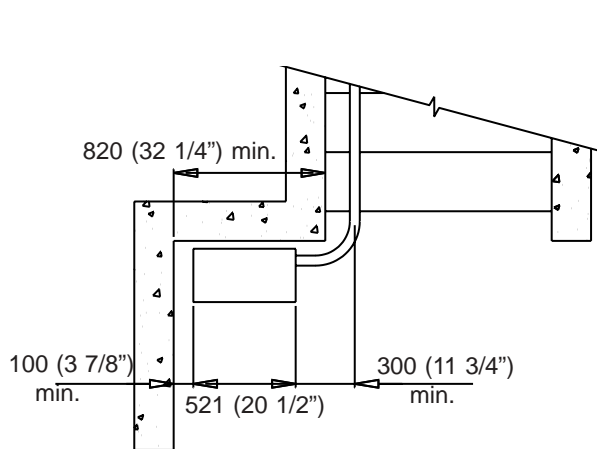

Note:

For 90° and 180° configurations, add 200mm (7 7/8") if the Call Station is mounted on the tubes.
 Drive Box dimensions: 1053mm (41 1/2") high x 521mm (20 1/2") wide x 270mm (10 5/8") deep (refer to page 12).

Compact Drive

The Compact Drive is designed to utilize a minimum amount of space, in some conditions as little as 203mm (8"). Required clearances vary with stair angle, motor orientation, as well as ramp and platform sizes. For further details on this drive system refer to page 12, and for lower landing considerations see page 16.

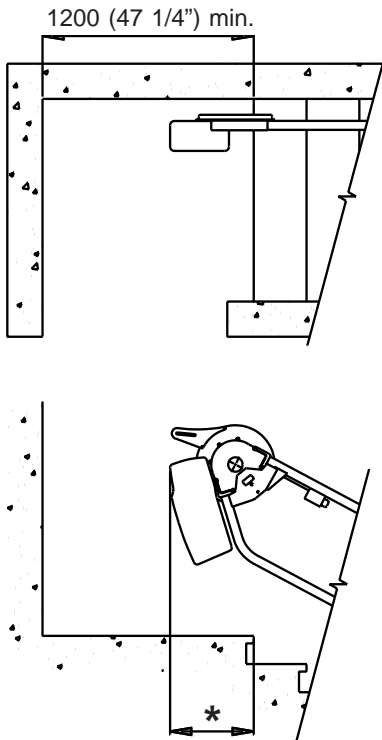

* 152mm (6") - 406mm (16")
Dimension variable with stair angle, motor orientation, ramp extensions and platform size.

Reverse Drive

By reversing the drive box it can be placed closer to the top stair nose, while still maintaining sufficient clearance for loading and unloading. This scenario is ideal for landings between stairs or where walls end at the top of the stairs.

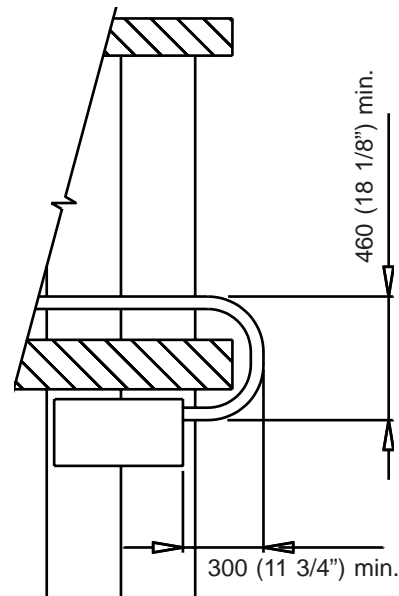
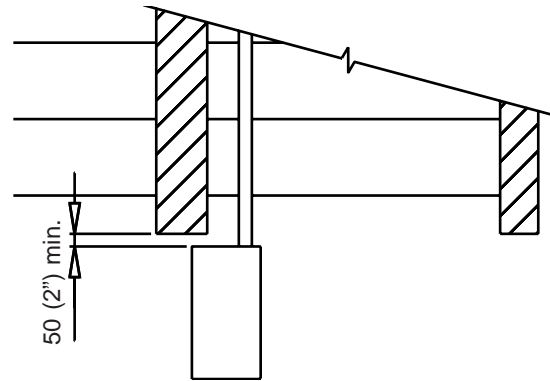

Alternate Drive Configurations

Drive on Treads - Flight Beyond Upper Landing
Designed for intermediate landings with restricted clearances due to narrow hallways, the drive box is mounted on the stair treads. This ensures maximum clearance on the landing for pedestrian traffic.

Drive Through Wall at 90° or 180°

The tubes go through the wall enabling the drive to be stored in a separate room instead of on the upper landing.

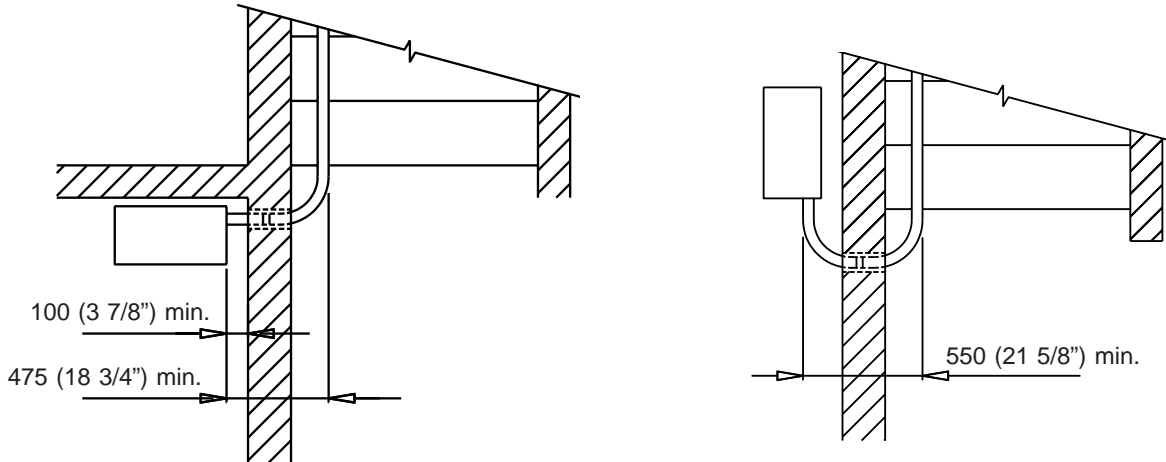

Drive Under Floor

The drive box can be positioned under the floor if sufficient clearances are available. It can be placed on its side or right side up.

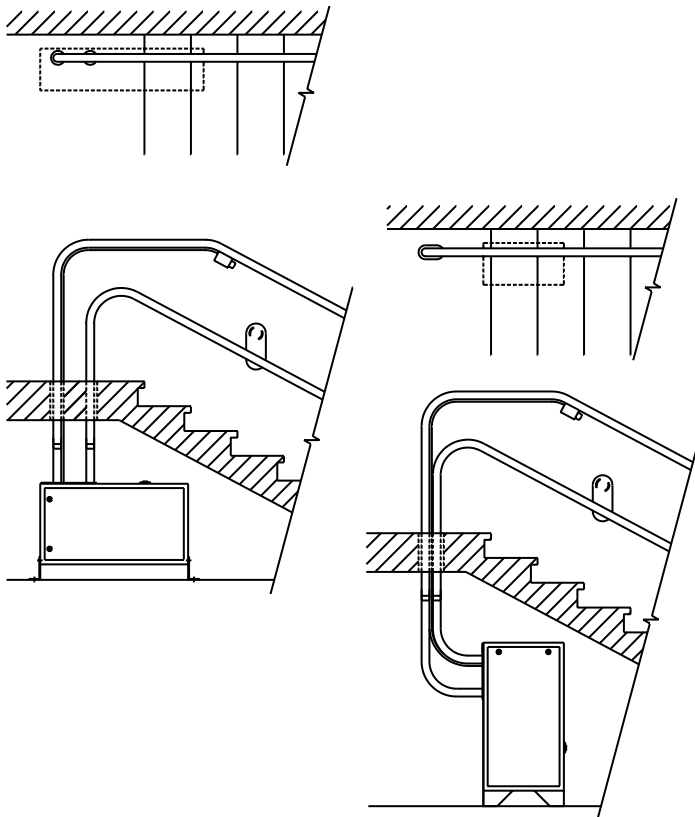

Drive on Shelf

The drive box can be attached to a shelf that is fastened to a solid wall.

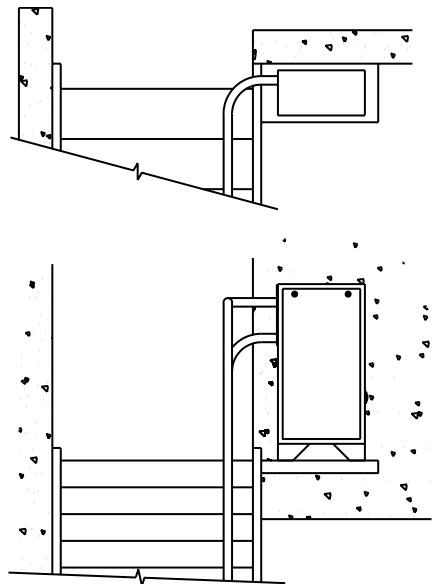

Platform Storage at Upper Landing (Optional)

This feature allows the platform to travel along the tubes, while folded, to a storage location off the stairs. A stabilizer tube is required for this application (see page 13 for stabilizer details). Other configurations are possible.

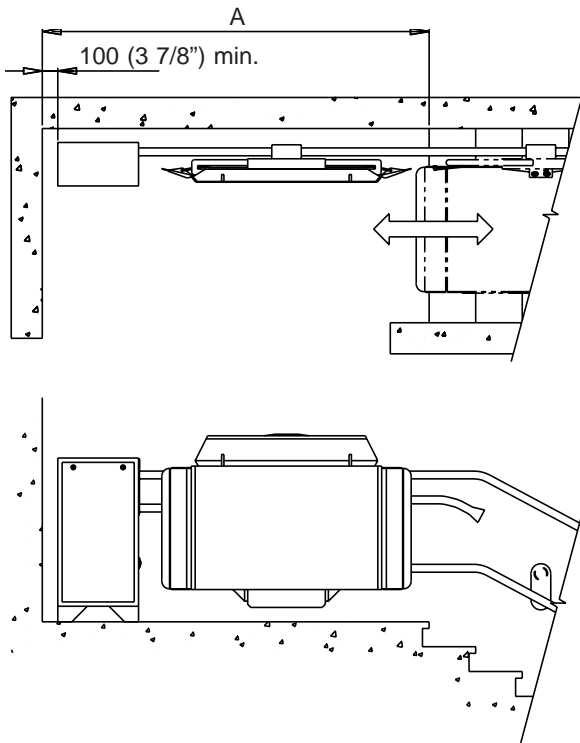

In-line Drive with Platform Storage

(Drive Box Shown, also available with Compact Drive)

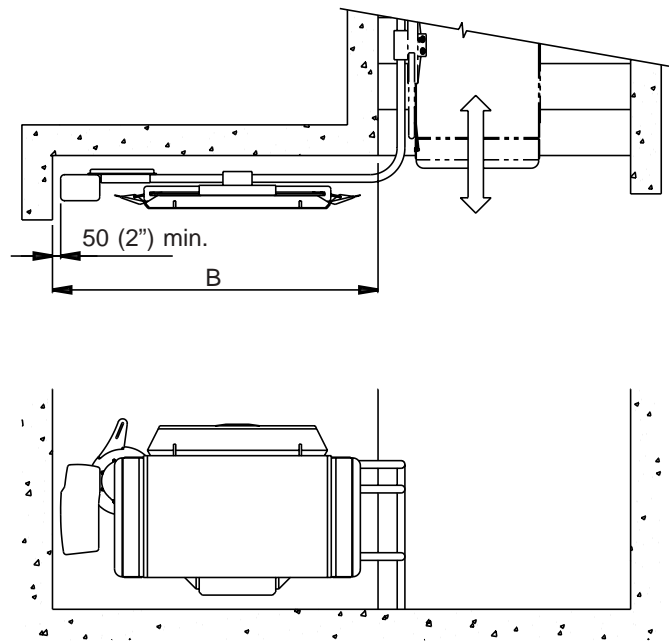

90° Drive with Platform Storage

(Compact Drive Shown, also available with Drive Box)

Dim.	Drive Arrangement	Platform Size							
		800 x 1220 mm (31 1/2" x 48")		800 x 1050 mm (31 1/2" x 41 3/8")		800 x 900 mm (31 1/2 x 35 3/8")		700 x 750 mm (27 1/2" x 29 1/2")	
		mm	in	mm	in	mm	in	mm	in
A	Drive Box	2350	92 1/2	2175	85 5/8	2020	79 1/2	1880	74
	Compact Drive	2035	80 1/8	1865	73 3/8	1715	67 1/2	1565	61 5/8
B	Drive Box	2245	88 3/8	2075	81 3/4	1925	75 3/4	1775	69 7/8
	Compact Drive	1935	76 1/8	1765	69 1/2	1615	63 5/8	1465	57 5/8

Notes:

- Dimensions for Compact Drives are approximate only. Factors affecting the location of the Compact Drive include stair angle, motor orientation and ramp extensions. Contact your local Garaventa representative or call the Garaventa Design Hot Line for more information.
- If the call station is mounted on the tubes, add 200mm (7 7/8") for drive box configurations.
- Dimensions are based on standard platforms with standard ramps. Ramp extensions will increase the clearance dimensions required.

Platform Running Clearances Required for Platform Folded Up

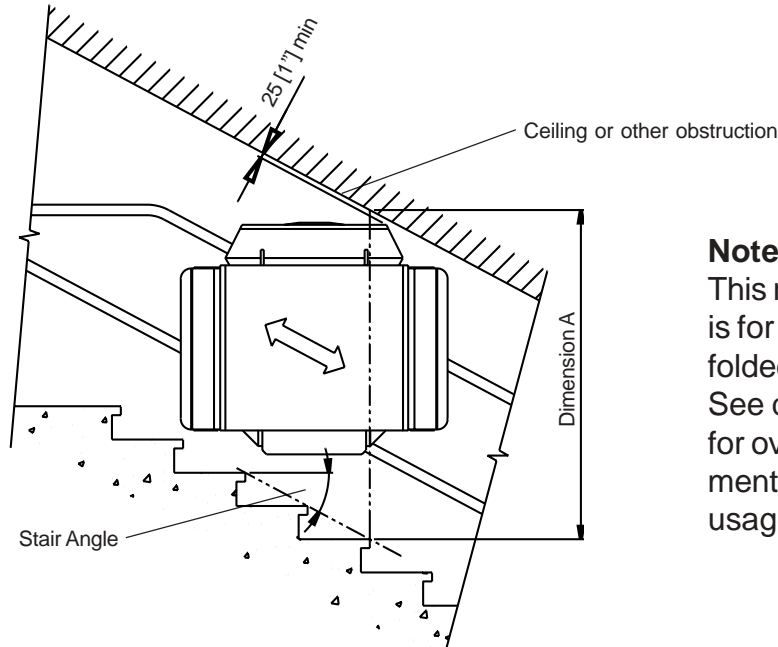

Note:
This running clearance is for the platform in the folded position only. See dimensions below for overhead requirements for passenger usage and codes.

Minimum Overhead Clearances to Meet Code Requirements

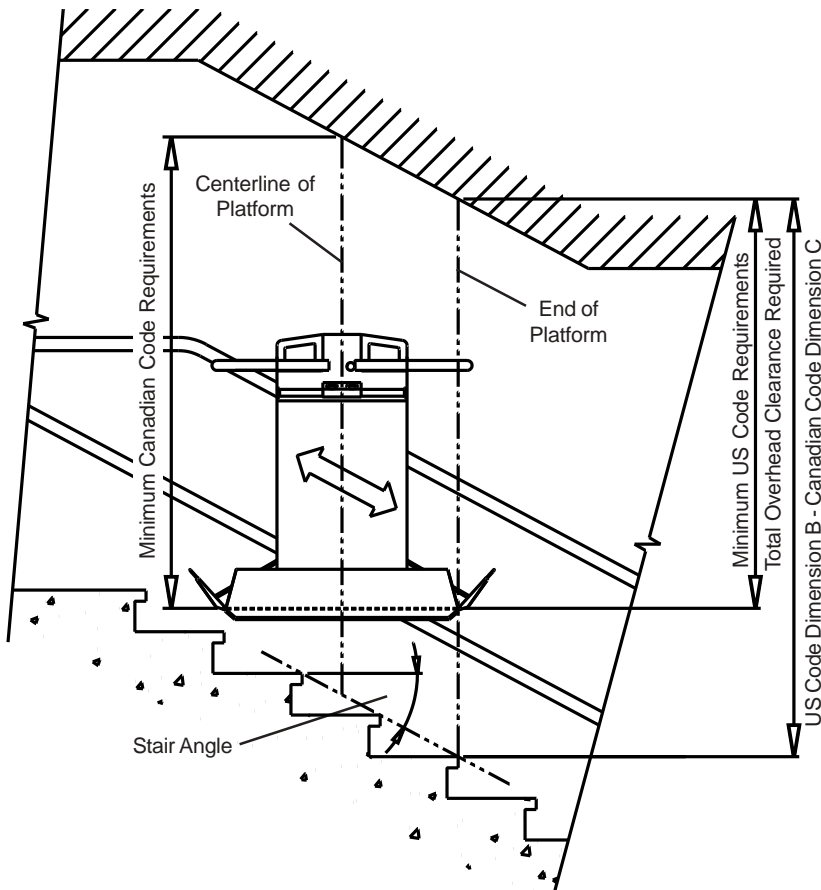

Minimum Code Requirements:
US Code (ASME A18.1b)
1524mm (60") overhead clearance required to any point above the platform deck. Refer to Dimension B in chart on page 25.

Canadian Code (CSA B355-2000)
1500mm (59") overhead clearance required to the centerline of the platform. Refer to Dimension C in chart on page 25.

Note: Please consult the local Garaventa representative for local code requirements.

Platform Running Clearances Required For Platform Folded Up

Dimension A Stair Angle	Platform Size							
	800 x 1220 mm (31 1/2" x 48")		800 x 1050 mm (31 1/2" x 41 3/8")		800 x 900 mm (31 1/2" x 35 3/8")		700 x 750 mm (27 1/2" x 29 1/2")	
	mm	in	mm	in	mm	in	mm	in
22°	1560	61 3/8	1500	59	1445	56 7/8	1330	52 3/8
25°	1690	66 1/2	1610	63 3/8	1540	60 5/8	1400	55 1/8
30°	1825	71 7/8	1730	68 1/8	1645	64 3/4	1475	58 1/8
35°	2000	78 3/4	1880	74	1775	69 7/8	1560	61 3/8
40°	2215	87 1/4	2070	81 1/2	1945	76 5/8	1685	66 3/8
45°	2460	96 7/8	2290	90 1/8	2140	84 1/4	1845	72 5/8

Clearances to Meet US Code Requirements (ASME A18.1b)

Dimension B Stair Angle	Platform Size							
	800 x 1220 mm (31 1/2" x 48")		800 x 1050 mm (31 1/2" x 41 3/8")		800 x 900 mm (31 1/2" x 35 3/8")		700 x 750 mm (27 1/2" x 29 1/2")	
	mm	in	mm	in	mm	in	mm	in
22°	2086	82 1/8	2020	79 1/2	1960	77 1/8	1880	74
25°	2170	85 3/8	2090	82 1/2	2020	79 1/2	1930	76
30°	2320	91 3/8	2220	87 1/2	2135	84	2020	79 1/2
35°	2480	97 5/8	2365	93 1/8	2260	89	2120	83 1/2
40°	2665	104 7/8	2525	99 3/8	2400	94 1/2	2235	88
45°	2880	113 3/8	2710	106 3/4	2560	100 3/4	2365	93

Note: Consult the local dealer representative for status of the new ASME A18.1b code requirements (some areas are exempt).

Clearances to Meet Canadian Code Requirements (CSA B355-2000)

Dimension C Stair Angle	Platform Size							
	800 x 1220 mm (31 1/2" x 48")		800 x 1050 mm (31 1/2" x 41 3/8")		800 x 900 mm (31 1/2" x 35 3/8")		700 x 750 mm (27 1/2" x 29 1/2")	
	mm	in	mm	in	mm	in	mm	in
22°	1820	71 5/8	1785	70 1/4	1755	69 1/8	1705	67 1/8
25°	1865	73 3/8	1825	72	1790	70 1/2	1730	68
30°	1945	76 5/8	1895	74 5/8	1850	72 7/8	1780	70
35°	2030	79 7/8	1970	77 1/2	1920	75 5/8	1835	72 1/4
40°	2130	83 7/8	2060	81 1/8	1995	78 1/2	1895	74 5/8
45°	2245	88 3/8	2160	85	2085	82 1/8	1965	77 3/8

Attachment Methods

Tube Attachments

To maintain the vertical separation between the tubes, distance struts and gussets are welded to the tubes. The struts are attached either directly to the wall or to square or rectangular steel support towers.

Please refer to the loading diagram on page 29 for wall and floor reactions.

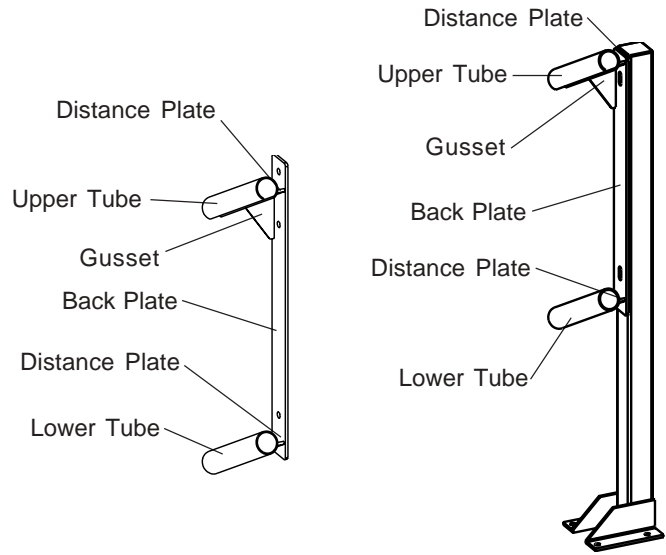

Direct Mount Strut

Tower Mount Strut

Solid Walls - solid concrete, concrete block, wood or steel reinforcement

This construction is ideal for direct mounting as the struts can be attached directly to the wall. Where extra support is necessary the upper hole in the strut can be fastened through the wall.

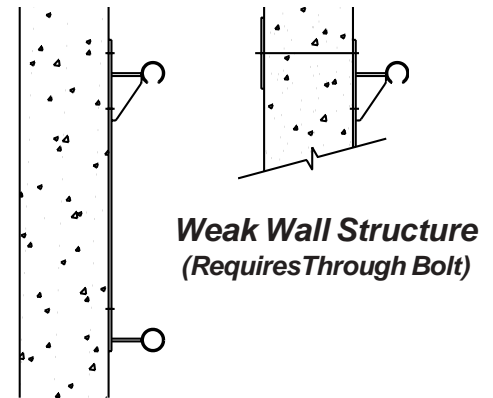

Direct Mount

Weak Wall Structure (Requires Through Bolt)

Wood Stud Walls

These structures require support towers, along with a 2" x 6" board that is screwed to the studs in the wall, running parallel to the stair flight. The towers must be attached to the board as well as to the floor or stair treads.

When using this attachment method, add the board thickness of 38mm (1 1/2") to the turning clearances shown on pages 18 & 19.

Note: This method of anchoring is not feasible for steel stud walls.

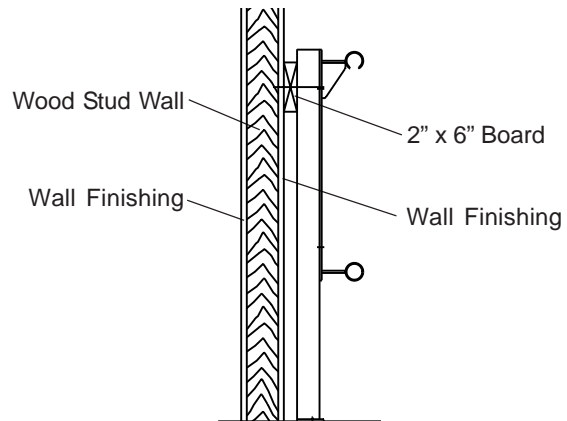

Tower Mount to 2" x 6" Board on Wall

Freestanding Support Towers - *solid concrete stairs, steel pan stairs filled with concrete, 76mm (3") thick wood stairs/landings*

These are required when there are no existing support walls, or when the lift is required to be freestanding.

For concrete-filled steel pan treads, the towers are either bolted through the treads (where access is possible) or attached to a steel stringer for additional support.

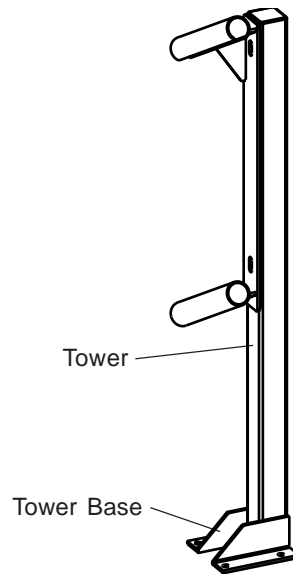

Freestanding Tower Mount

Please refer to the loading diagram on page 29 for wall and floor reactions.

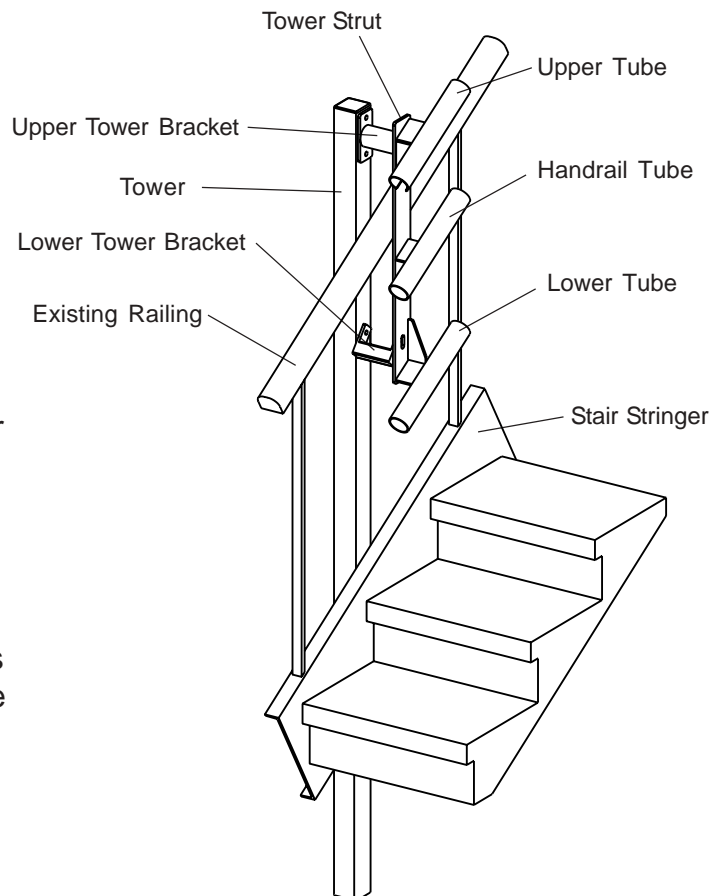

Tower Mount in Open Balustrade

Open Balustrade - *towers in the core*

Towers can be positioned within the open stair core when there is insufficient platform turning clearances or if the stairs are too weak for freestanding towers. The towers are fastened to the walls, stringers, or stair edge, as well as to the floors.

Handrails can be removed or special brackets can be used to allow for tube attachment to the towers, without damaging the balustrade.

Wall Height Requirements for Direct Mounting

For prevention of concrete breakout, these required wall heights include 100mm (3 7/8") of clearance from the top hole of the strut to the top of a concrete wall.

Stair Angle	Platform Size							
	800 x 1220 mm (31 1/2" x 48")		800 x 1050 mm (31 1/2" x 41 3/8")		800 x 900 mm (31 1/2" x 35 3/8")		700 x 750 mm (27 1/2" x 29 1/2")	
	mm	in	mm	in	mm	in	mm	in
20°	1155	45 1/2	1125	44 1/4	1095	43 1/8	1055	41 1/2
25°	1230	48 3/8	1190	46 7/8	1155	45 1/2	1100	43 1/4
30°	1315	51 3/4	1270	50	1225	48 1/4	1155	45 1/2
35°	1410	55 1/2	1355	53 3/8	1300	51 1/8	1215	47 7/8
40°	1520	59 7/8	1450	57 1/8	1385	54 1/2	1285	50 5/8
45°	1645	64 3/4	1560	61 3/8	1485	58 1/2	1365	53 3/4

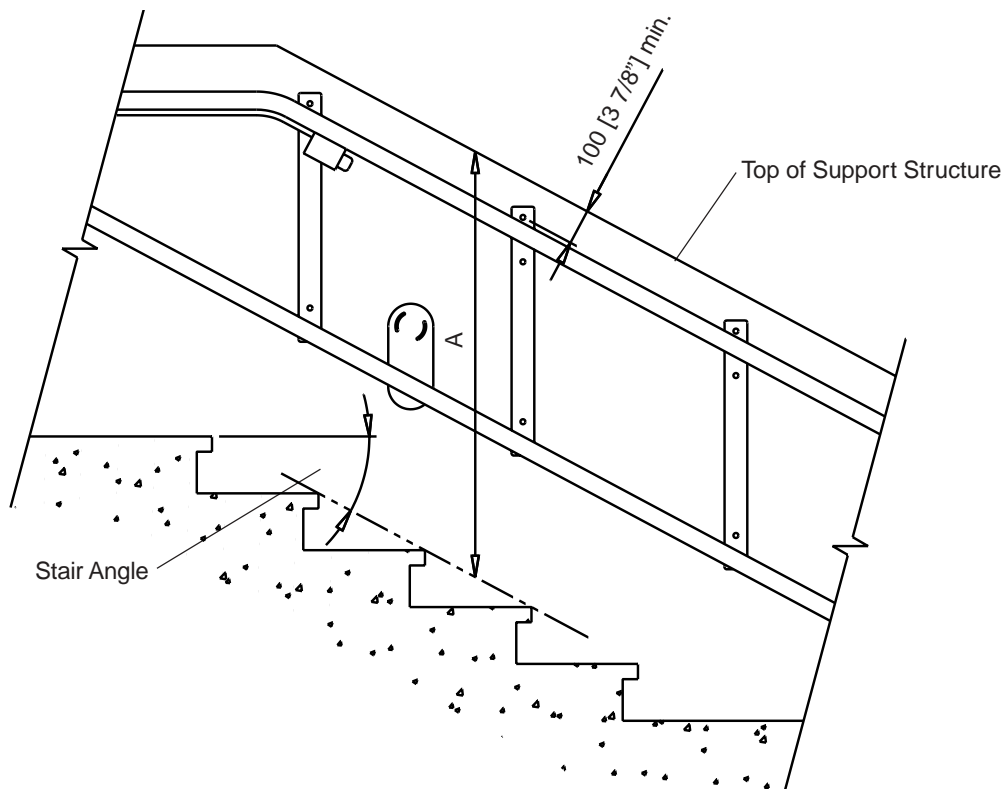

Minimum Support Structure Height for Direct Mounting on Concrete Wall

Loading Diagram

Loads are based on an 800 x 1220mm (31 1/2" x 48") platform:

Straight Lifts and/or Lifts with Inside Radius Bends:

- F1= 1078.7 N (242.5 lbf)
- F2= 2451.7 N (551.2 lbf)
- d1= 276mm (10 7/8")
- d2= 488mm (19 1/4")

Moment at the center of tower or back of direct mount strut

- M= F x d (F: Force; d: distance)
- M= F1 x (d1 + X) + F2 x (d2 + X)

Tower Mount

X is 92mm (3 5/8") min. to 330mm (13") max.

Direct Mount

X is 100mm (4.0") min. to 140mm (5 1/2") max.

Maximum Moment

- M= 2659.2 Nm (23535.6 lbf in) with Tower Mount
- M= 1988.4 Nm (17598.8 lbf in) with Direct Mount

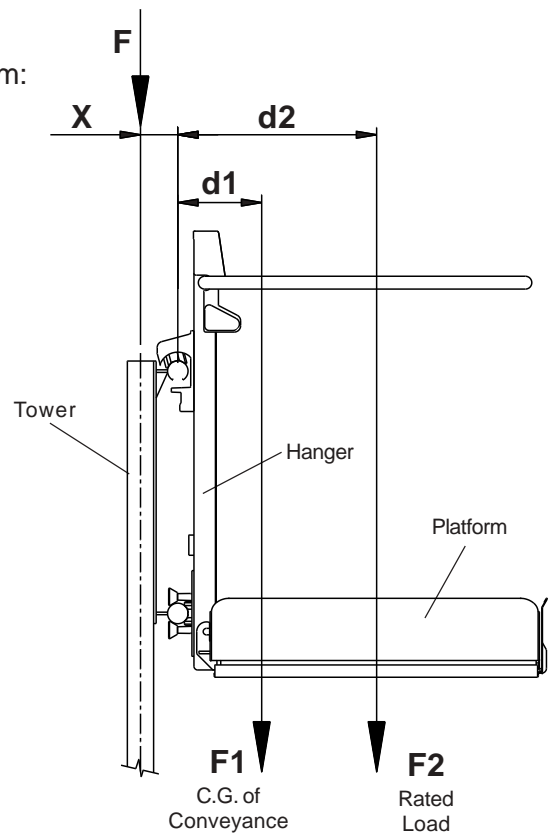

Lifts with Outside Radius Bends:

- F1= 1216.0 N (273.4 lbf)
- F2= 2451.7 N (551.2 lbf)
- d1= 341mm (13 3/8")
- d2= 588mm (23 1/8")

Moment at the center of tower or back of direct mount strut

- M= F x d (F: Force; d: distance)
- M= F1 x (d1 + X) + F2 x (d2 + X)

Tower Mount

X is 92mm (3 5/8") min. to 330mm (13") max.

Direct Mount

X is 100mm (4.0") min. to 140mm (5 1/2") max.

Maximum Moment

- M= 3066.6 Nm (27141.5 lbf in) with Tower Mount
- M= 2369.7 Nm (20973.8 lbf in) with Direct Mount

**GARAVENTA STAIR-LIFT
GSLARTIRA**

Serial Number: _____

Rated Load: 250 kg / 550 lbs

Rated Speed: _____

Rated Voltage: 208-240 VAC, 50/60 HZ

Rated Current: 20 A

Weight of Car: 121 kg / 265 lbs

Suspension: Rope Sprocket

Date of Manufacture: _____

Installed By: _____

Installation Date: _____

CSA B44.1 / ASME A17.5

www.garaventalift.com

ACCESSIBILITY

Certified for CSA B-355 Electrical Safety
 Built in accordance with: CSA B44.1 / ASME A17.5, CSA B-355, ASME A18.1, ASME A17.1, ISO 9986-2
 ELEVATING DEVICE FOR PERSONS WITH DISABILITIES.

Technical Reference of Standard Features

Platform Sizes:	800 x 1220mm (31 1/2" x 48") 800 x 1050mm (31 1/2" x 41 3/8") 800 x 900mm (31 1/2" x 35 3/8") 700 x 750mm (27 1/2" x 29 1/2")
Curved Safety Arms:	Fully automatic, 32mm (1 1/4") diameter safety arms, top of arm 948mm (37 3/8") above platform deck.
Pedestrian Safety Lights:	Illuminated tube lighting, located at both ends of the platform deck. Alerts pedestrians that the platform is in motion.
Rated Load:	250 kg. (550 lbs.)
Speed:	6 meters (20 ft) per minute, slowing to 3 meters (10 ft) through corners and when approaching or departing landings.
Operating Controls:	
Call Stations (Standard):	Equipped with Garaventa Smart-Lite Technology™, constant pressure directional buttons, one touch fold & unfold buttons, 24VDC power, and keyed operation
Platform (Standard):	Equipped with constant pressure switches, 24VDC power, Emergency Stop Button (manual reset) and keyless operation
Drive System:	
Motor:	3 phase (supplied by inverter) 1.5 H.P. drive box located at the end of the guide tube system. The drive box can be located away from the upper landing by extending the guide tubes.
Power Requirements:	The mains power requirement for both drive systems is 208-240 VAC, 50/60 HZ single phase on a dedicated 20 amp. circuit.
Power Transmission:	Roped sprocket using 8mm (3/8") wire haul rope.
Emergency Use:	Ratchet wrench (or handwheel) is provided.
Overspeed Safety:	Located at the bottom of the tube assembly containing mechanical overspeed sensor and brake, with electrical drive cut-out protection.
Rail System:	Two 51mm (2") O.D. steel tubes spaced 600mm (23 5/8") apart vertically.
Finishes:	Durable electrostatically applied and baked fine textured Satin Grey paint.

A variety of optional features and custom modifications are available. To find out about custom features not included in the GSL Artira Design and Planning Guide and code requirements for your area consult your local representative or Garaventa.

Typical Wiring Layout

Actual wiring and number of conductors may vary depending on options, quantity of stations and lift configuration. Some of the options that will affect the wiring include:

- Emergency Stop switches (requires 2 additional conductors to each call station)
- Additional Audio Visual Alerts (requires 3 additional conductors to each A/V)

The following options require field wiring by others:

- Attendant Call
- Fire Service
- Auxiliary Power System
- and possibly others

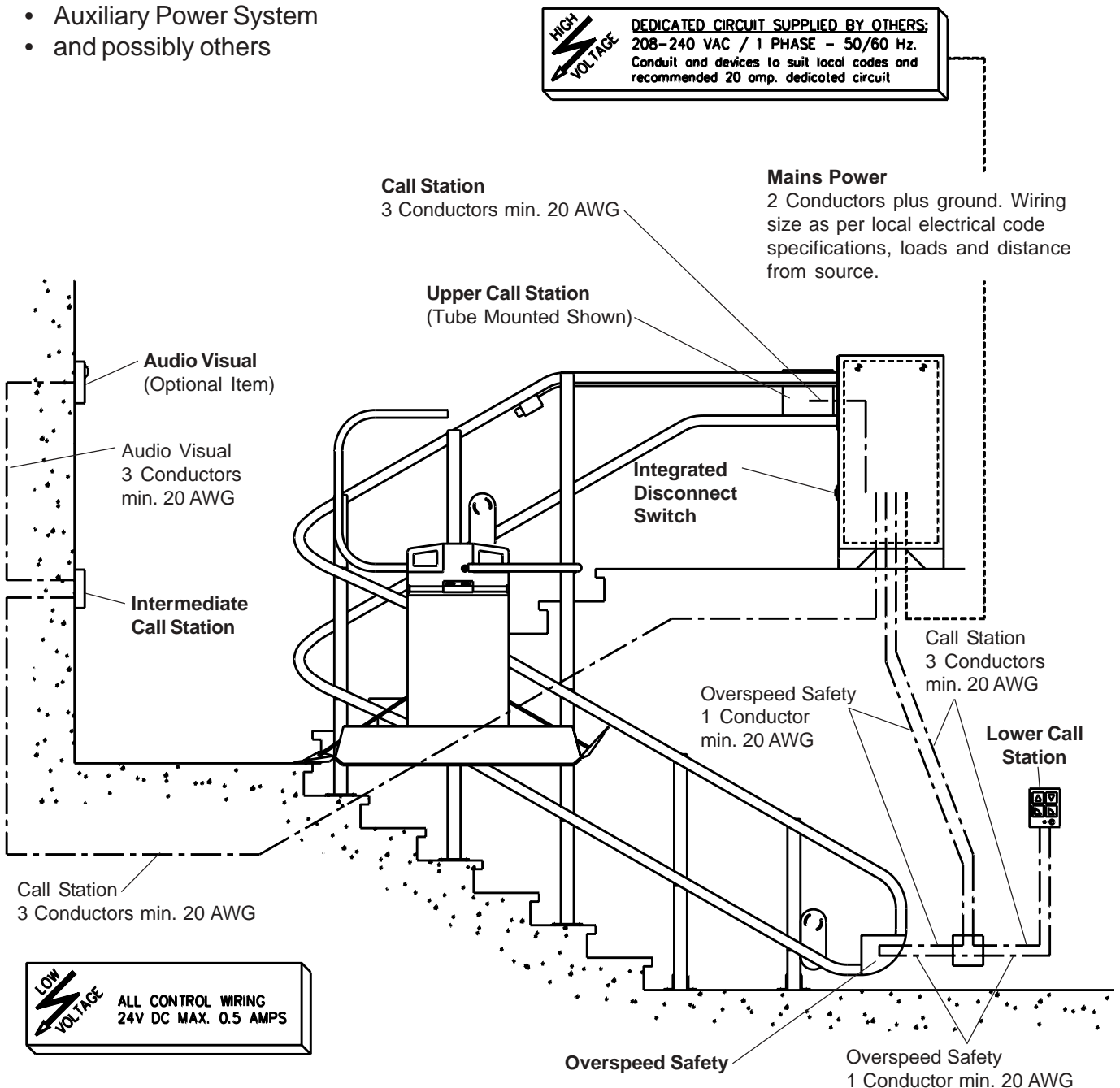



Garaventa Stair-Lift

Inclined Wheelchair Platform Lift

Model: GSL ARTIRA

For Straight and Turning Stairways

Need Assistance Writing the Specification?

GSL Artira specifications will vary from one building site to another based on the stairway configuration, building materials, user requirements and local codes. **Your Local Authorized Garaventa Dealer has the expertise to assist and develop an appropriate design specification for your accessibility project.**

Authorized Garaventa Dealers can be found Worldwide, call or email Garaventa for the Dealership nearest you.

In addition, professional designers at Garaventa Accessibility are available to answer your technical questions and to assist you with the design and specs.

Garaventa Accessibility

Phone: (604) 594-0422 **Fax:** (604) 594-9915

Toll Free: 1-800-663-6556

web Site: www.garaventa.ca

Email: productinfo@garaventa.ca

Other Garaventa Accessibility products include:

Stair-Lift GSL Xpress - Inclined Platform Lift for straight stairways

Genesis Enclosure and Shaftway - Vertical Platform Lift for lifting heights up to 4267mm (14')

Genesis OPAL - Vertical Platform Lift for lifting heights up to 1448mm (57")